

SCOUT **5500**

new!



officine
PICCINI

Caracteristici tehnice

SCOUT
5500



MOTOR	PERKINS 1106C-60TA sau DEUTZ BF4M
PUTEREA	148/112 sau 148/112 (CP/Kw)
TRANSMISIE	HIDROSTATICA
TRACTIUNE PE 4 ROTI	✓
VITEZE HIDROSTATICE PROGRESIVE	2+2
VITEZA MAXIMA	30Km/h
ROTI DIRECTIONALE	4
3 MODALITATI DE DIRECTIE	✓
FRANI PE DISCURI MULTIPLE IN BAIE DE ULEI	✓
REZERVOR DE MOTORINA	120 Lt.
REZERVOR ULEI HIDRAULIC	140 Lt.
RAZA DE COTIRE INTERNA/EXTERNA	2,34/4,79 m
CAPACITATE CUPA DE INCARCARE	650 Lt.
ULUC DE DESCARCARE COMANDAT HIDRAULIC	✓
VOLUM TOTAL TAMBUR DE AMESTECARE	8300 Lt.
PRODUCTIA DE BETON	5800 Lt.
INCLINATIA TAMBURULUI	14°
CAPACITATEA REZERVORULUI DE APA	950 Lt.
CONTOAR LITRI	✓
PNEURI	18/22,5
LANCE DE SPALARE	✓
CABINA ROPS-FOPS	✓
GREUTATEA OPERATIVA	6.500kg

DIMENSIUNI:

A	2500
B	2400
C	1940
D	3500
D1	3060
E	4033
F	1604
G	2600
H	1800
L	6004
M	7260
N	420
O	1470

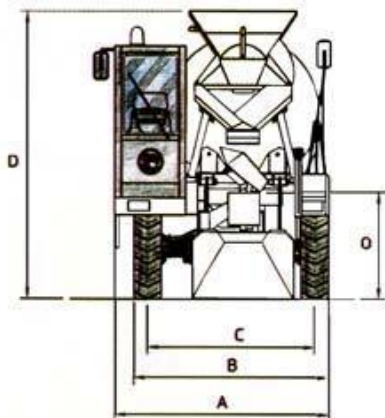

ACCESORII :

- SISTEM DE CANTARIRE PE CUPA DE INCARCARE
- SISTEM DE CANTARIRE PE TAMBUR
- POMPA DE MARE PRESIUNE PENTRU SPALARE
- INSTALATIE DE LUMINI PENTRU CIRCULATIE
- SNEC HIDRAULIC PENTRU SACI

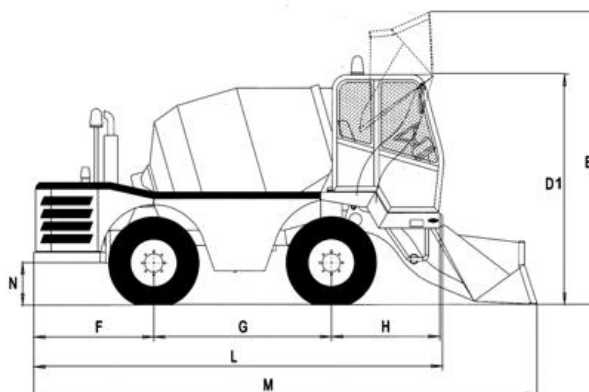
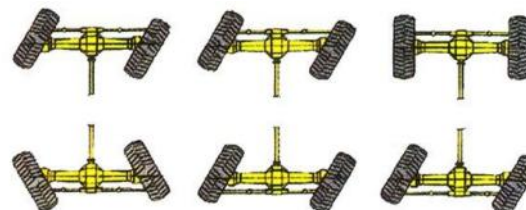

Reprezentant zonal



Contact: Girov - Neamt, D.N. 15D, km 9+565
tel: 0233/290.301 fax: 0233/290.302
e-mail : contact@piccini.ro
web : www.piccini.ro